

HC2006

Sero! Telephone
Installation & Fitting Instructions

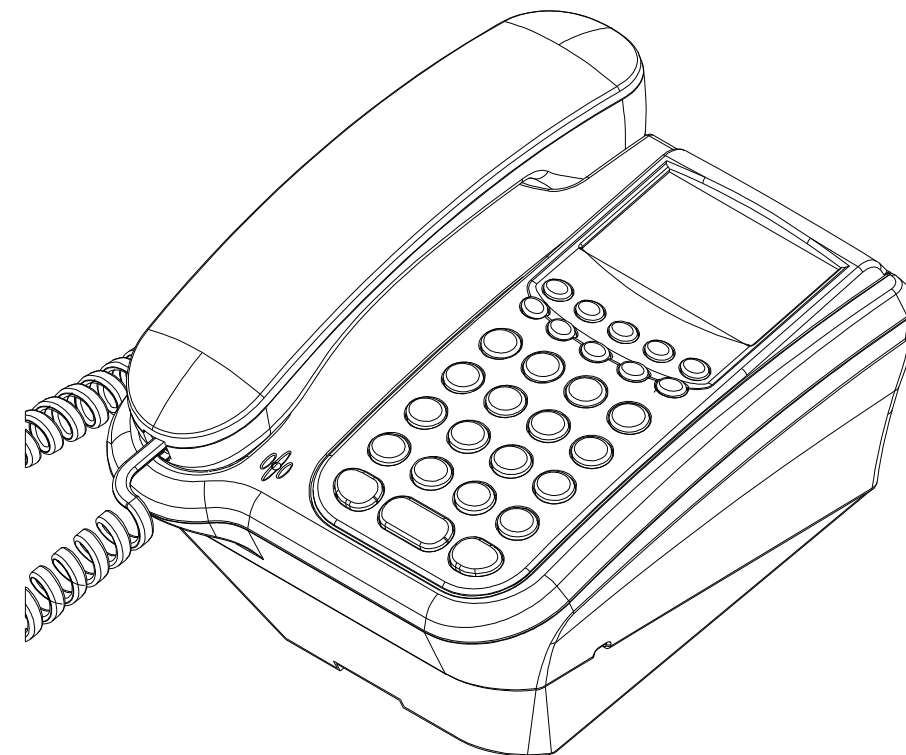

TELEPHONE
FAX
email
website

01296 461000
01296 461001
sales@possum.co.uk
<http://www.possum.co.uk>

KEYPAD / BATTERY COMPARTMENT REMOVAL DETAILS

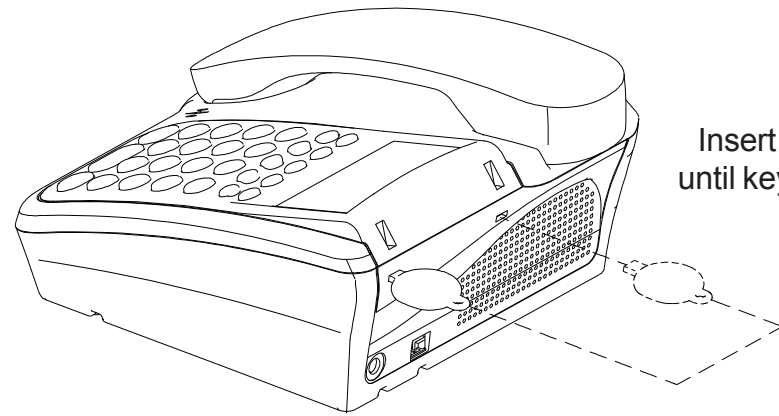

STEP 1
Insert removal key into each slot as shown, until keypad catch 'clicks' and keypad section lifts slightly.

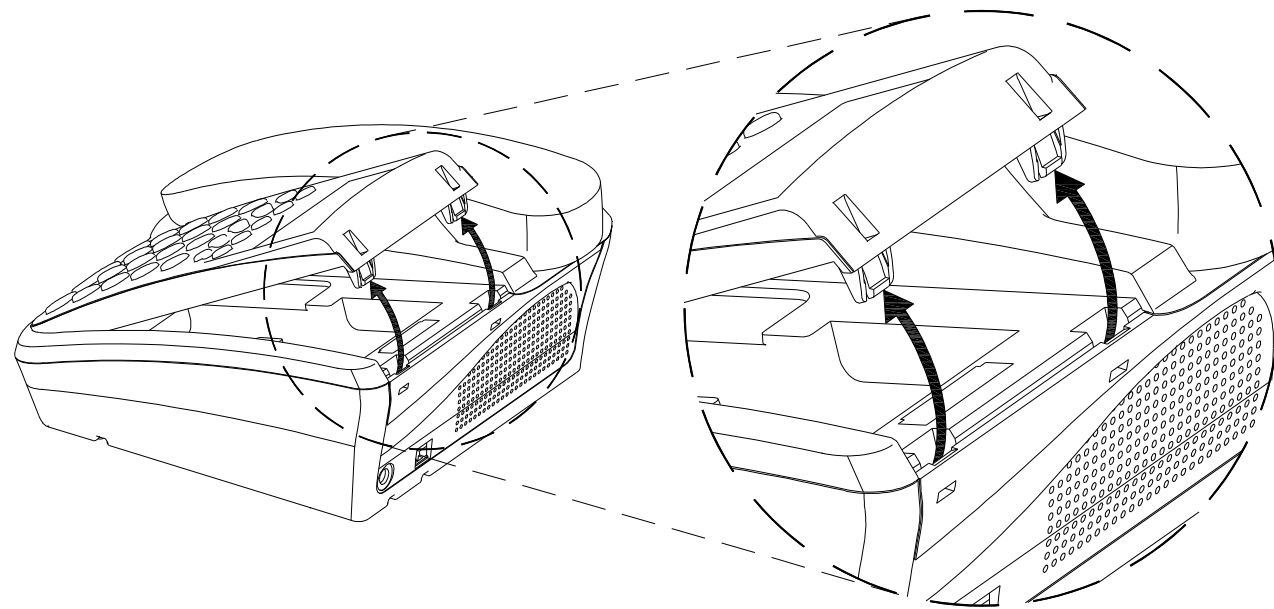

STEP 2
Pivot keypad section up from rear of unit by hand and then slide it free from the main body of the telephone.

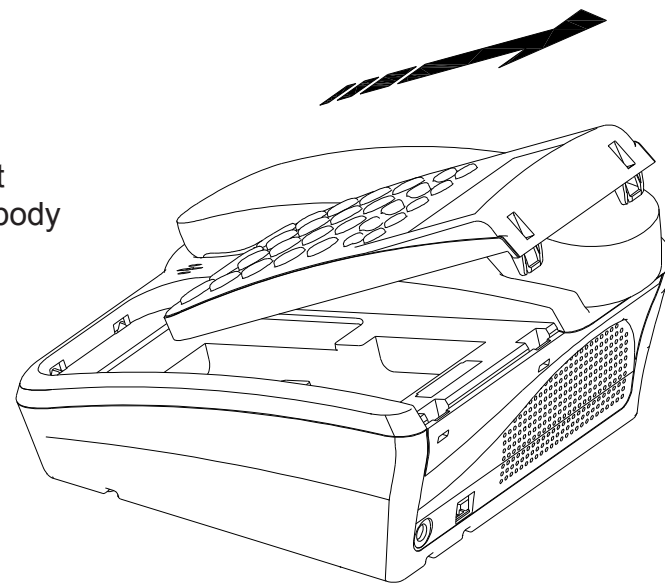

WALL MOUNTING DRILLING TEMPLATE

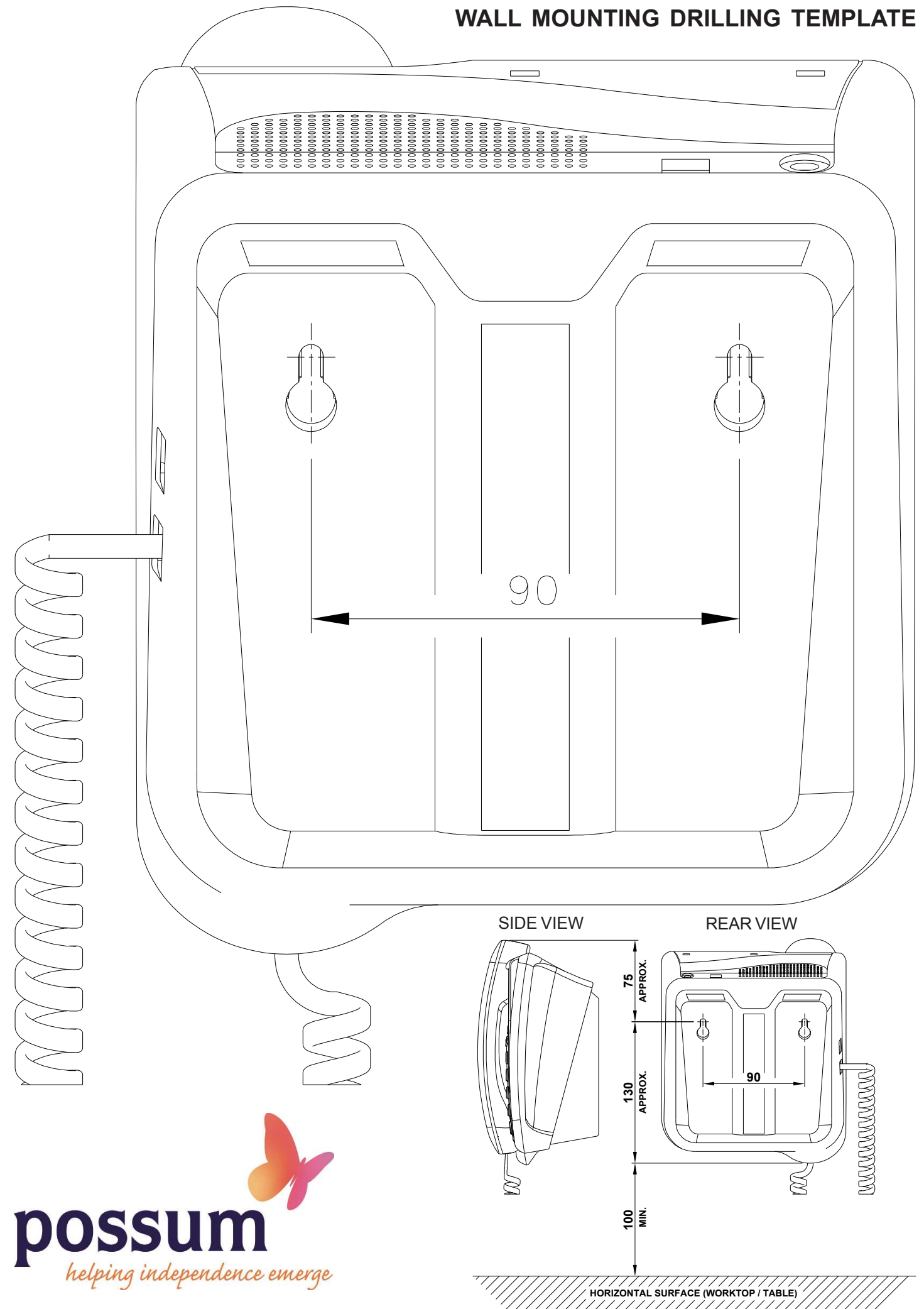

WALL MOUNTING INSTRUCTIONS

1. MARKING OUT

Use page 7 of this guide as a template. When positioning the telephone make sure that the screws avoid all utilities.

2. CONCRETE AND BRICK WALLS.

Use No. 8 pan head screws. Using masonry drill bit, drill and fit suitable wall plugs, as per manufacture's instructions. Insert Wall plugs and fit screws, leaving head proud by 5mm.

3. STUD OR PARTITION WALL.

Using a locating device, find the position of studs (framework). Mount using No. 8 pan head screws, leaving head proud by 5mm. Alternatively, use appropriate hollow wall fixings.
(Do not use standard wall plugs)

4. POSITIONING

Do not position over sources of direct heat, such as radiators or fires or in direct sunlight. Do not position telephone where it will be susceptible to damage, such as entrances to rooms etc. See over leaf for size constraints.

Remove bung feet in base of telephone unit before fixing to mounting bracket and re-fit them in the mounting base. Telephone will then simply clip into place.

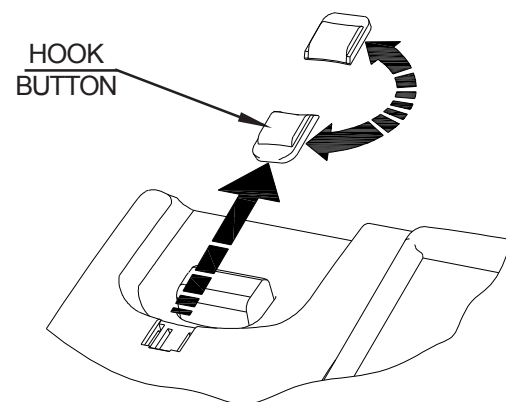

NOTE

To ensure that the handset sits securely in place when the telephone is mounted vertically, the hook button will need to be removed and rotated through 180 degrees and then replaced.

To remove the hook button, use a suitable flat object, that will not cause damage, lever hook button out from its socket and replace it with the extended section protruding.

CARE SHOULD BE TAKEN TO AVOID INJURY!

BATTERY INSERTION DETAILS

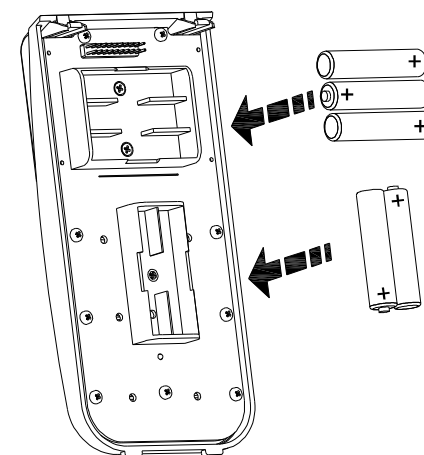

STEP 1
Insert the 5 off 'AAA' size Ni-MH Rechargeable batteries (Part No.355-038) Ensure correct orientation.

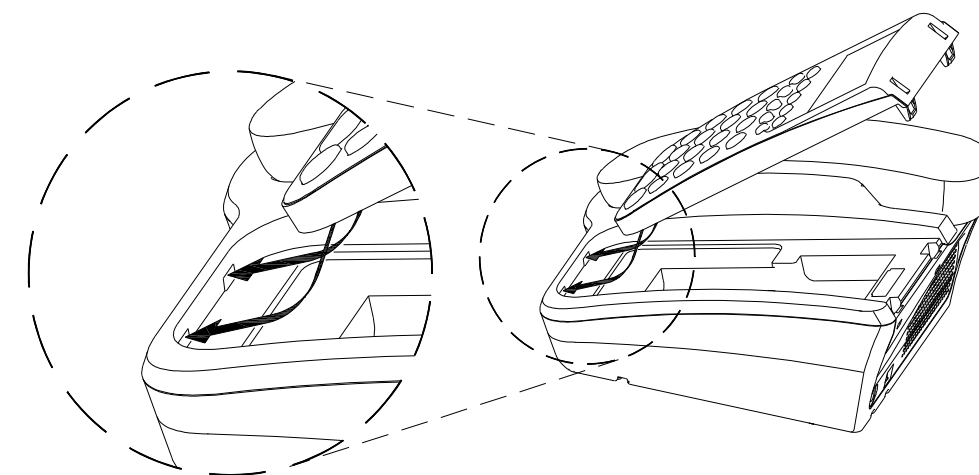

STEP 2
Locate lugs on front end of keypad into sockets on main body of telephone.

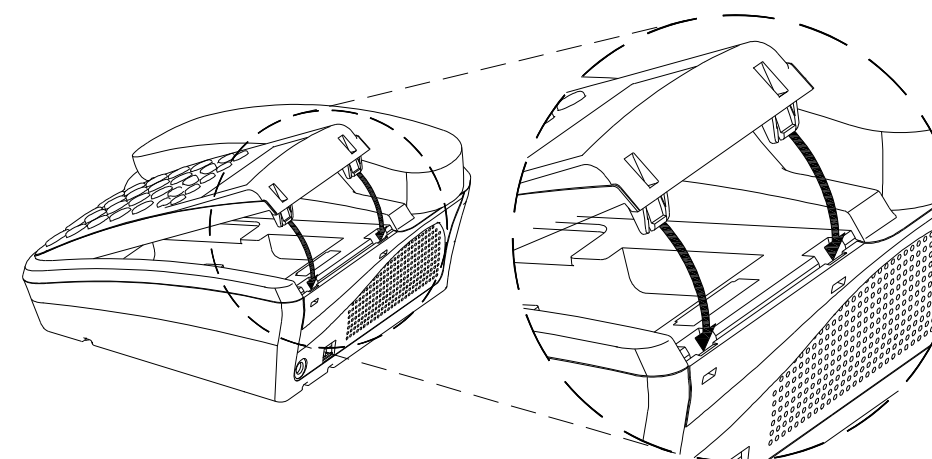

STEP 3
Lever keypad down until a positive 'click' is heard from both fixing lugs.

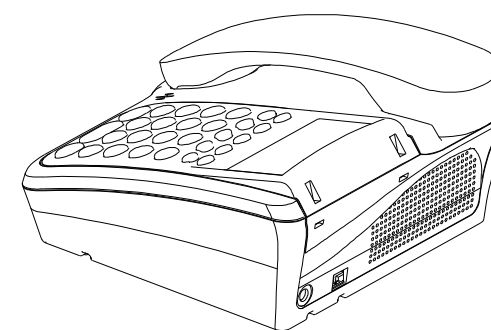

STEP 4
Ensure keypad is properly located onto main body of the telephone.

CONNECTION DETAILS

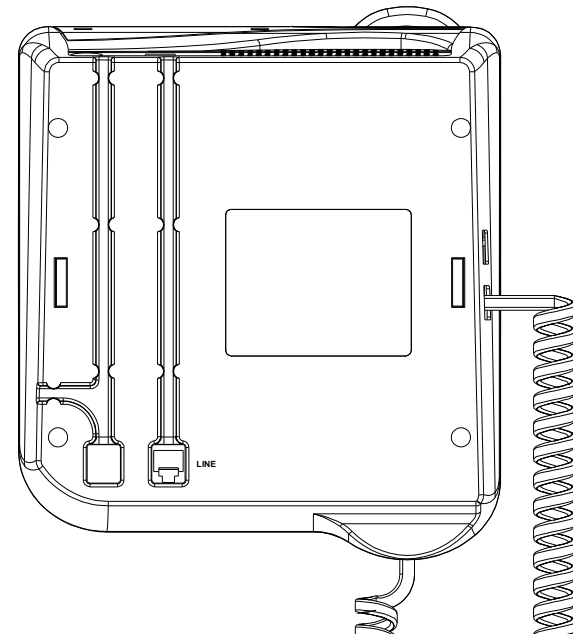
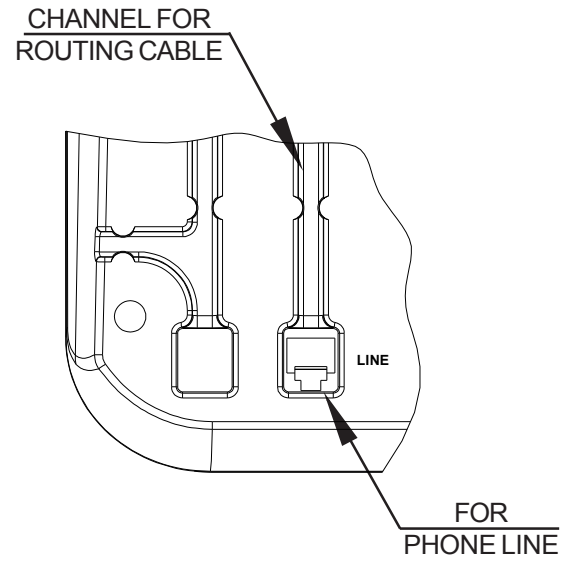

VIEW ON UNDERSIDE

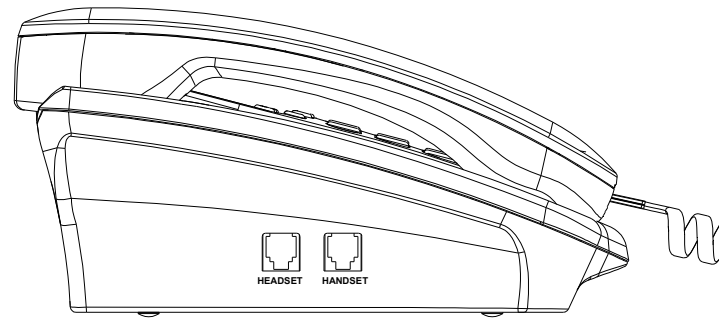
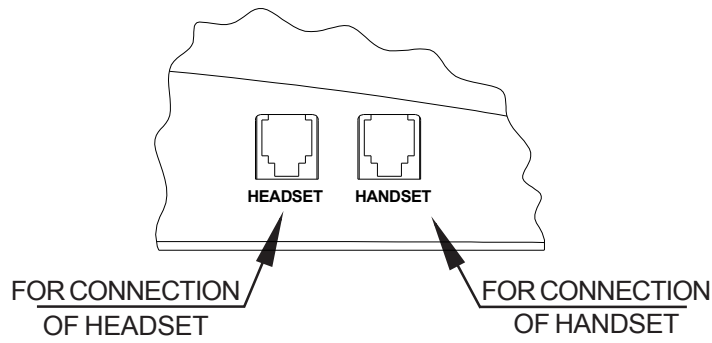

VIEW ON SIDE

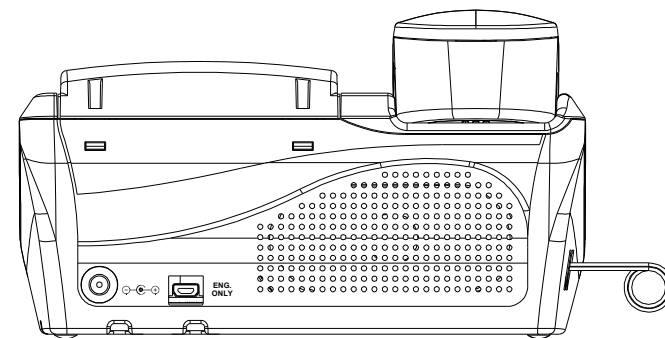
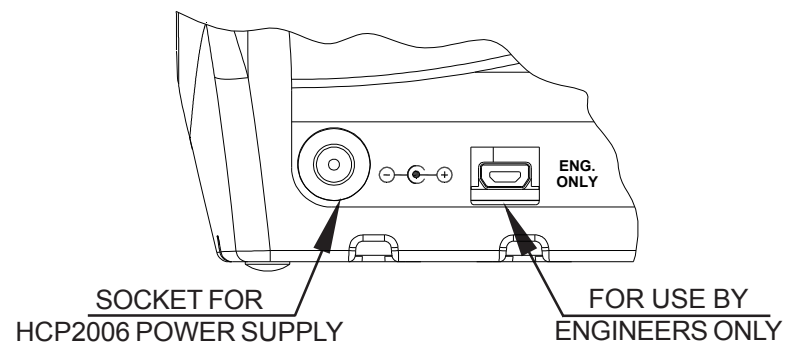

VIEW ON END

FITTING MOUNTING BASE

FITTING FOR VERTICAL MOUNTING

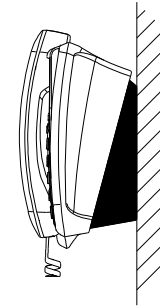

NOTE
Remove all bung feet from underside of telephone and re-fit them to the mounting base. Clip mounting base into position.

(See mounting instructions for full details)

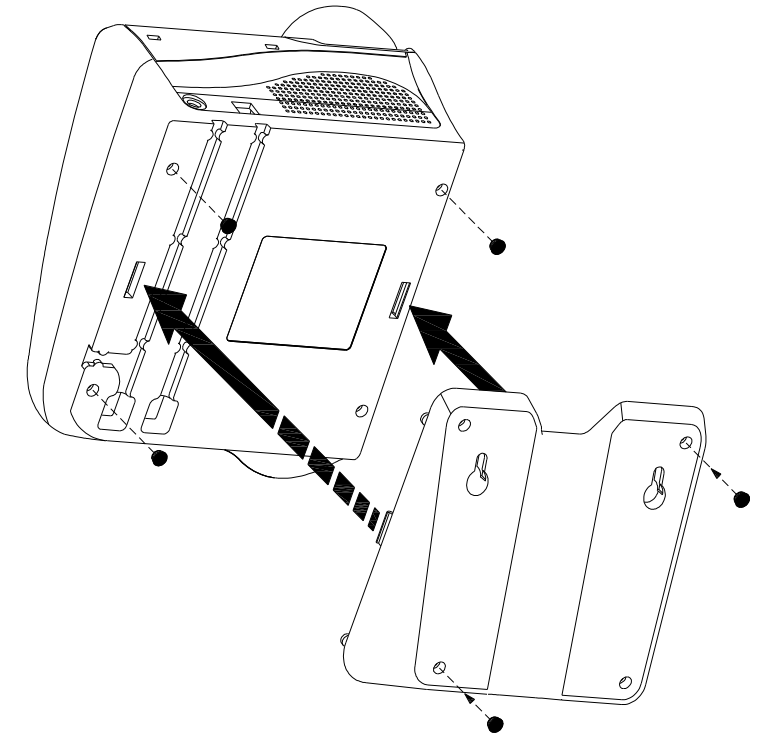

FITTING FOR ELEVATED HORIZONTAL MOUNTING

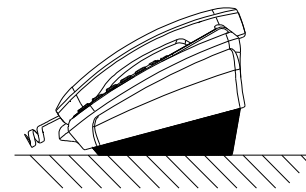

NOTE
Remove all bung feet from underside of telephone and re-fit them to the mounting base. Clip mounting base into position.

